



domnick hunter

HIGH PRESSURE FILTERS

Compressed Air and Gas Purification for High Pressure Systems.

The new **domnick hunter OIL-XPLUS** high pressure filters combine the well proven **OIL-XPLUS** filter elements with specially designed housings for the finest purification of high pressure compressed air and gases.

They are available in various grades of filtration and housing materials to suit applications such as air-blast circuit breakers, oxygen filtration for breathing gas mixtures, high pressure blow moulding of plastics, gas filtration for diving bells, filtration of natural gas, starting air for diesel engines and high pressure breathing air systems.

STANDARD FEATURES:

- For working pressures up to 350 bar g (5075 psi g) and flow rates up to 100 L/sec (210 scfm)
- Available in four filtration grades
- Complete with domnick hunter quality OIL-XPLUS filter elements
- Tie-rod fixing of elements for positive location
- Suitable for use when mineral, synthetic or even degraded lubricants are present
- Corrosion resistant filter housings manufactured in HE30TF aluminium. (304 stainless steel or Incoloy 825 are available on request)
- 1/4" to 3/4" BSPP female pipe connections available (NPT available on request)

OIL-XPLUS



- All housings hydraulically tested and manufactured from certified materials
- Available oxygen cleaned if required
- Air bleed/drain screw provided with safety-cover

BENEFITS:

- Clean, high pressure compressed air and gases
- Protection of processes and products
- Low operating cost
- Easy installation
- Low maintenance

TECHNICAL SPECIFICATIONS:

Maximum Operating Pressure:-
350 bar g (5075 psi g)

Maximum Operating Temperature:-
GRADE PF, AO, AA: 66°C (150°F)
GRADE AC: 30°C (86°F)

Minimum Operating Temperature:-
1.5°C (35°F)

Operating Pressure Differential at Rated Flow:-
GRADE PF: 500 m bar (7.5 psi) approx
GRADE AO: 500 m bar (7.5 psi) approx
GRADE AA: 500 m bar (7.5 psi) approx

***Recommended Filter Element Change:-**
12 months or 6000 hours*

*Not applicable to Grade ACS elements. Grade ACS elements should be changed after 1000 hours operation at 21°C (70°F) or before if odours can be detected.

PERFORMANCE SPECIFICATIONS:

GRADE PF - General Purpose Pre-Filter

For the removal of particles down to 25 microns and bulk liquids in installations where gross contamination is a problem.

GRADE AO - High Efficiency Pre-Filter

For the removal of particles down to 1 micron including coalesced liquid water and oil providing a maximum remaining oil aerosol content of 0.5 mg/m³ @ 21°C (70°F).

GRADE AA - High Efficiency Oil Removal Filter

For the removal of particles down to 0.01 micron including water and oil aerosols, providing a maximum remaining oil aerosol content of 0.01 mg/m³ @ 21°C (70°F).

GRADE AC - Activated Carbon Filter

For the removal of oil vapour and hydrocarbon odours giving a maximum remaining oil content of less than 0.01 mg/m³ @ 21°C (70°F). The Grade AC Filter **WILL NOT** remove CO/CO₂ or other toxic gases or fumes. If CO/CO₂ removal is required, please ask for details of the **domnick hunter** high pressure compressed air breathing air purifiers.

FILTER SELECTION & DIMENSIONS:

MODEL NO.	PIPE CONNS. BSPP FEMALE	MAX. WORKING PRESSURE	FLOWRATE (ANR) AT 350 bar g (5075 psi g)	REPLACEMENT ELEMENT CODE	DIMENSIONS mm (ins)				APPROX WEIGHT
					A	B	C	D	
HP006 PF	G ¹ / ₄	350 bar g 5075 psi g	25 L/s 53 scfm 90 Nm ³ /hr	K009 PF	76.2 (3.0)	225 (8.9)	50 (1.9)	125 (4.9)	2.4 kg 5.3 lbs
HP006 AO	G ¹ / ₄			K009 AO					
HP006 AA	G ¹ / ₄			K009 AA					
HP006 AC	G ¹ / ₄			K009 ACS					
HP013 PF	G ¹ / ₂	350 bar g 5075 psi g	50 L/s 105 scfm 180 Nm ³ /hr	K017 PF	101.6 (4.0)	270 (10.6)	60 (2.4)	150 (5.9)	4.85 kg 10.7 lbs
HP013 AO	G ¹ / ₂			K017 AO					
HP013 AA	G ¹ / ₂			K017 AA					
HP013 AC	G ¹ / ₂			K017 ACS					
HP025 PF	G ³ / ₄	350 bar g 5075 psi g	100 L/s 210 scfm 360 Nm ³ /hr	K030 PF	101.6 (4.0)	305 (12.0)	60 (2.4)	180 (7.1)	5.3 kg 11.7 lbs
HP025 AO	G ³ / ₄			K030 AO					
HP025 AA	G ³ / ₄			K030 AA					
HP025 AC	G ³ / ₄			K030 ACS					

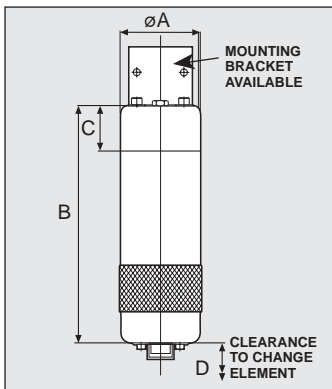

To obtain flow rates in Nm³/hr multiply L/sec by 3.6
Use the correction factors below for flow rates at other working pressures:

Working Pressure	bar g	50	100	150	200	250	300	350
	psi g	725	1450	2150	2900	3625	4350	5075
Correction Factor		0.38	0.53	0.65	0.76	0.85	0.93	1.00

dh, domnick hunter and OIL-X are registered trademarks of domnick hunter limited

domnick hunter limited has a continuous policy of product development and although the Company reserves the right to change specifications, it attempts to keep customers informed of any alterations. This publication is for general information only and customers are requested to contact our Industrial Division Sales Department for detailed information and advice on a products suitability for specific applications. All products are sold subject to the Company's standard conditions of sale.



pure innovation

a member of the domnick hunter group plc

UK • AUSTRALIA • BRAZIL • CANADA • CHINA • DENMARK • FRANCE • GERMANY • JAPAN • MALAYSIA • SINGAPORE • SPAIN • THAILAND • USA



Copyright domnick hunter limited 1996
Publication Reference: 34 5/96 Rev 001
Stock No: 17 400 4434